

XEBEC Floating Holder Instruction Manual (FH-ST12-SL10)

Read this instruction manual before using this product. Failure to do so can result in serious injury or death. This instruction manual must be kept in the vicinity of the machine at all times so that it is accessible to the operator.

Features

- The built-in spring makes the tool holding tube float, and this allows stable processing via load control with the machine tool.
- It can be used on machining centers, NC lathes, drilling machines, special machines, and other machine tools.
- It is possible to change the cutting load according to the processing quality required.
- Edge quality stabilized by offsetting changes in the cutting amount caused by tool wear.
- Reduces frequency of adjustments required to compensate for changes to depth of cut and bristle length.
- Reduces tool wear by stabilizing processing conditions.

This document may also be viewed at the below website:
https://www.xebec-tech.com/instruction_manual/



- This product is an optional tool designed exclusively for XEBEC Brush Surface. (FH-ST12-SL10: φ6, φ15, φ25, φ40)
- Do not attach a tool other than the XEBEC Brush Surface.
- Also read the XEBEC Brush Surface Instruction Manual.

SAFETY PRECAUTIONS

Be sure to observe the methods described in this manual.

Using the product in ways inconsistent with the methods described in this manual may result in serious injury or death.

⚠ WARNING

- There is the risk of operator loss of sight or injury resulting from this product detaching from the machining equipments, bristles breaking off, workpieces breaking, etc.
- Fragments, cutting particles, burrs, etc., occur due to processing with this product, and these can pierce the eyes or skin of operators causing loss of sight and injury.
- Dust occurring as a result of processing with this product can cause lung damage, irritate skin, and bring on allergic reactions.
- Even if there is no problem at the pre-work check, if vibration or other abnormality occurs during use, discontinue use immediately. Continuing to use the product when there is an abnormality presents the risk of operator loss of sight or injury resulting from this product detaching from the machining equipments, bristles breaking off, workpieces breaking, etc.
- Do not use the product while exceeding the maximum rotational speed, depth of cut, or brush projection, as there is the risk of operator loss of sight or injury resulting from this product detaching from the machining equipment, bristles breaking off, workpieces breaking, etc.
- Use the XEBEC Brush Surface suitable to the applicable brush diameter, and use the bush matching the shank diameter of the XEBEC Brush Surface. There is the risk of operator loss of sight or injury resulting from this product detaching from the machining equipment, parts breaking, etc., if a tool or bush not suitable to the appropriate shank diameter is used.
- When chucking, slide the sleeve shank of the XEBEC Brush Surface all the way to the end of the tool holding tube of this product or bush (the sleeve flange end should directly contact the end of the tool holding tube or the bush). Using the product in ways inconsistent with the methods described in this manual presents a risk of operator loss of sight or injury resulting from this product detaching from the machining equipment, parts breaking, etc.
- Do not press the floating function in further than the permissible operating range (6 mm). Using the product in a way that is not consistent with the methods of this manual presents a risk of operator loss of sight or injury resulting from this product detaching from the machining equipment, parts breaking, etc.

NOTICE

As a result of the above, there is also the risk of damage to machines, jigs, and workpieces.

Operator Safety Protection

⚠ Use of protective equipment

Be sure to wear personal protective gear including goggles, masks, gloves, and earmuffs. Wear clothing with long sleeves or other clothing that does not expose the skin, and fasten the cuffs and hems tightly.

⚠ Attention to the work area

- Install an enclosure so that persons other than the operator do not enter the work area, and ensure that all persons, if any, in the work area are wearing protective equipment.
- Keep the floor of the work area clean at all times to prevent the risk of slipping or tripping on dust, cutting particles, oil, water, or other substance.
- There is the risk of fire caused by heating, sparks, or other factor resulting from use of the product. Do not use the product close to a flammable liquid or in an explosive atmosphere.
Also be sure to enact fire prevention measures.

⚠ Precaution regarding cutting particles

Fragments, cutting particles, and other substances generated during work will be scattered into the surrounding area. Be sure to use a dust collector or other means to collect them.

Pre-Work Check

Perform test operation for 1 minute or more before starting work, and for 3 minutes or more after the machine tool or product was changed, and check that there is no looseness, vibration, or other abnormality of the machine and the part where the product is installed.

Precautions for Use

- Ensure there are no loose screws before use.

Installation onto a machining center or other machine

⚠WARNING: When chucking, slide the shank onto the chuck of the machining equipment securely all the way to the base.

- If not inserted all the way to the base when chucked, vibration during machining may cause this product to fall from the machining equipment. There is the risk that this may cause operator loss of sight or injury.
- When installing, use a chuck that is correct for the shank diameter.
- Install and use on machining equipment that can control the rotational speed.
- Do not use through-spindle coolant. If coolant gets inside the holder, the floating function may not work properly.
- When using on a horizontal machining center, the floating function may not work if the spring load is low. Make sure you perform an operational check before use.
- You cannot use the product on machining paths with intermittent sections where the XEBEC Brush Surface may fall or where there are protrusions where the floating function cannot work.
- When the product is used with precision machining equipment, there is the risk that cutting particles may have an adverse effect on the equipment sliding parts. Be sure to properly collect cutting particles and wash thoroughly.

When wet machining

Do not aim coolant directly at the floating holder. If dust or coolant gets into the holder, the floating function may not work properly.

When dry machining

Use a dust collector to collect the dust that is generated by machining. If dust gets into the holder, the floating function may not work properly.



XEBEC TECHNOLOGY CO.,LTD.
Fuerte Kojimachi 1 • 7 Building, 1-7-25,
Koujimachi, Chiyoda-ku, Tokyo, 102-0083, Japan
TEL. +81-3-6893-0810 FAX. +81-3-5211-8964
© 2019 XEBEC TECHNOLOGY CO.,LTD.

XEBEC Floating Holder Instruction Manual (FH-ST12-SL10)

Specifications

Dimensions

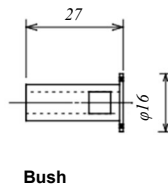
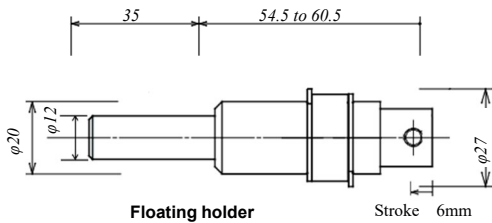

Tool specifications

Target brush diameter (mm)	Bush	Diameter of sleeve shank on the brush (mm)	Maximum rotational speed (min ⁻¹)	Floating stroke (mm)
φ6	XBS1006	φ6	10000*	6
φ15			6000*	
φ25	XBS1008	φ8	5000*	
φ40	Not required	φ10	3000*	

The maximum rotational speed is according to the XEBEC Brush™ Surface Instruction Manual.

Set the optimum rotational speed.

* The maximum rotational speed for this product as a stand-alone unit is 10000min⁻¹.

Spring specifications

Spring type		Spring load (N)		Diameter (mm)	Free length (mm)	Maximum deflection (mm)	Spring constant (N/mm)
		0mm stroke	6mm stroke				
Built in	Standard load	4.5	6.3	φ10	40	24	0.3
	Attached	Low load	1.5		3.3	30	18
High load		7.2	10.5		39	22.6	0.55

Fitting the brush

- When fitting the bush, align the shank screw holes with the setting mark, push the bush all the way in, then secure the shank screw.
- To fit the XEBEC Brush Surface, slide the shank all the way to the end of the tool holding tube, then firmly tighten the shank screws.

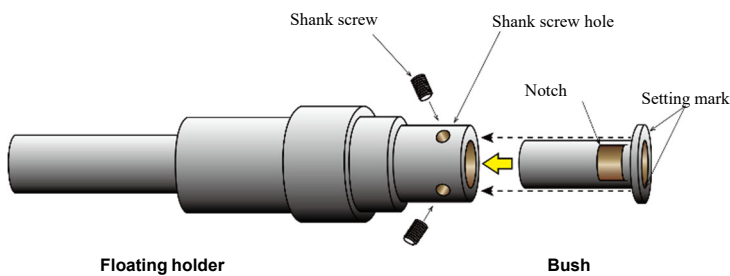

Effective use

The following describes effective use of the tool.

- ① Introduce the brush from above the workpiece while it is not in motion.
- ② Cut to the set value and compress the spring.
- ③ After compressing the spring, rotate the brush and start feeding.
- ④ When machining is completed, stop rotating the brush and stop feeding.
- ⑤ Return the brush above the workpiece.

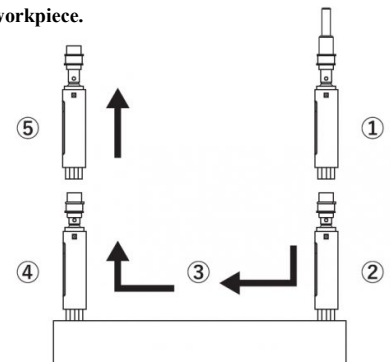

Maintenance and replacement of the spring

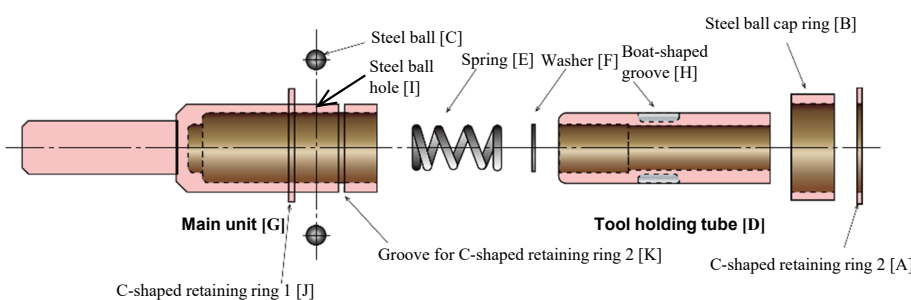

- Be careful not to get your fingers caught when attaching the steel ball cap ring.
- Tighten the screws, etc., with the standard torque.
- Use steel balls recommended by XEBEC.
- Regular maintenance is recommended. The interval between maintenance depends on the frequency of use.
- Sliding parts may seize when left unused for long periods. Make sure to perform maintenance before storing the product.
- When assembling or disassembling the C-shaped retaining ring, use snap ring pliers for C-shaped internal rings (ring size: 20 mm).

- ① Remove C-shaped retaining ring 2 [A].
- ② Remove the steel ball cap ring [B] and take out the steel balls [C] (2) from inside the main unit.
- ③ Remove the tool holding tube [D] from the main unit and take out the spring [E] and washer [F].
- ④ Wipe off the dirt inside of the main unit [G] and on the tool holding tube [D].
- ⑤ Apply grease sparingly to the sliding section (tool holding tube [D]).
 - Recommended grease: Lithium soap grease (NLGI no.2)
- ⑥ Confirm that there is no dirt on the tool holding tube [D] or inside the boat-shaped grooves [H].
- ⑦ Fit the spring [E] and washer [F] to the tool holding tube.
 - Use springs recommended by XEBEC.
- ⑧ Align the boat-shaped grooves [H] on the tool holding tube [D] and the steel ball hole [I] on the main unit.
- ⑨ Insert the steel balls [C] (2), attach the steel ball cap ring [B], then fit the C-shaped retaining ring 2 [A] into the groove for the C-shaped retaining ring 2 [K].
- ⑩ Press the bottom of the tool holding tube [D] with your finger and confirm that the tool holding tube [D] slides 6 mm.