

XEBEC Brush™ Crosshole Instruction Manual

Read this instruction manual before using this product. Failure to do so can result in serious injury or death. This instruction manual must be kept in the vicinity of the machine at all times so that it is accessible to the operator.

SAFETY PRECAUTIONS

Be sure to observe the contents of this manual. Using the product in a way that is not consistent with the contents of this manual may result in serious injury or death.

WARNING

- There is the risk of operator loss of sight or injury resulting from this product detaching from the processing apparatus, bristles breaking off, workpieces breaking, etc.
- Fragments, cutting particles, burrs, etc., occur due to processing with this product, and these can pierce the eyes or skin of workers causing loss of sight and injury.
- Dust occurring as a result of processing with this product can cause lung damage, irritate skin, and bring on allergic reactions.
- Even if there is no problem at the pre-work check, if vibration or other abnormality occurs during use, discontinue use immediately. Continuing to use the product when there is an abnormality presents the risk of operator loss of sight or injury resulting from this product detaching from the processing apparatus, bristles breaking off, workpieces breaking, etc.
- If the rotational speed exceeds the maximum, there is the risk of operator loss of sight or injury resulting from this product detaching from the processing equipment, bristles breaking off, workpieces breaking, etc.
- Machining at a constant point for a prolonged time causes the tip of the tool to become hot which presents the risk of operator loss of sight or injury resulting from bristles coming loose or breaking off. Adjust the processing times on locations being processed so that it does not become hot. Also be careful not to touch the locations being processed directly with bare hands after use.
- Use the tool suitable to the hole diameter. There is the risk of operator loss of sight or injury resulting from bristles breaking off, parts breaking, etc., if a tool not suitable to the hole diameter is used.
- Start rotation of the tip of the tool after it has been inserted into the cylinder to be machined. Using the product in ways other than described in this document or rotating it outside the cylinder presents a risk of operator loss of sight or injury resulting from the bristles breaking off and being flung.
- The following examples illustrate situations that present the risk of operator loss of sight or injury resulting from bristles breaking off, etc.
 - T-shaped workpiece: The diameter of the cross hole is more than 100% the size of the diameter of the main bore (e.g., main bore diameter is 10 mm, cross hole diameter is more than 10 mm)
 - Cross-shaped workpiece: The diameter of the cross hole is more than 70% the size of the diameter of the main bore (e.g., main bore diameter is 10 mm, cross hole diameter is more than 7 mm)

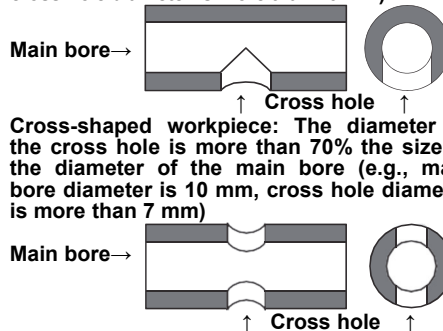

NOTICE

Furthermore, as a result of the situations described above, there is also the risk of damage to machining tools, jigs, and workpieces.

Operator Safety Protection

Use of protective equipment

Be sure to wear personal protective gear including goggles, masks, gloves, and earmuffs to prevent injuries common during machining. Wear clothing with long sleeves or other clothing that does not expose the skin, and fasten the cuffs and hems tightly.

Attention to the work area

- Install an enclosure so that persons other than the operator do not enter the work area, and ensure that all persons, if any, in the work area are wearing protective equipment.
- In particular be careful that children do not enter the work area.
- Keep the floor of the work area clean at all times to prevent the risk of slipping or tripping on dust, cutting particles, oil, water, or other substance.
- There is the risk of fire caused by heating, sparks, or other factor resulting from use of the product. Do not use the product close to a flammable liquid or in an explosive atmosphere. Also be sure to enact fire prevention measures.

Precaution regarding cutting particles

Fragments, cutting particles, and other substances generated during work will be scattered into the surrounding area. Be sure to use a dust collector or other means to collect them.

Pre-Work Check

Perform test operation for 1 minute or more before starting work, and for 3 minutes or more after the machine tool or product is changed, and check that there is no looseness, vibration, or other abnormality of the machine and the part where the product is installed. When doing this, start rotation with the tool tip inserted 20mm or more into the inside of the main bore.

Precautions for Use

Installation onto a machining center or other machine

When the product is used with precision machining equipment, there is the risk that cutting particles may have an adverse effect on the equipment sliding parts. Be sure to properly collect cutting particles and perform washing.

WARNING: When installing onto processing equipment, grip the tool shank by 30mm or more. If gripped with a grip length other than the specified one, this product may fall from the processing equipment due to vibrations during the machining. There is the risk that this may cause operator loss of sight or injury.

- When installing, use a chuck that is correct for the shank diameter.
- Install and use on processing equipment that can control the rotational speed.

Features

- Centrifugal force generated by rotation causes the brush to expand and remove fine burrs from the crosshole inside the cylinder.
- It polishes and removes black scale from the inside surface of the cylinder, and removes cutting particles and foreign substances from the hole bottom surface.
- The abrasive material is ceramic fiber that contains no abrasive grains at all.
- The brush tip generates grinding power. The tip of the bristle removes burrs and finishes the edges.
- Install onto a machining center, robot, or other processing equipment to remove burrs and cutter marks.
- The original brush material (ceramic fibers) enables consistent deburring and polishing capability without changes to the cutting performance or brush shape.

How to Use

This product is used for removal of post-machining fine burrs with a burr root thickness of 0.1 mm or less, and for removal of fine burrs from the inside of cylinders with inner diameters of $\phi 3.5$ mm - $\phi 20$ mm.

Definitions of cross hole and burrs with this tool

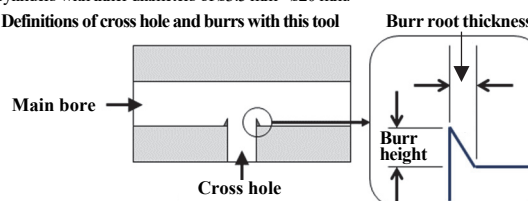

Maximum rotational speed

Use within the range shown below.

Product code / Bristle Color		Target hole diameter	Maximum rotational speed (min ⁻¹)
Red	Blue		
CH-A12-1.5M		$\phi 3.5 - 5$	20000
CH-A12-3M	CH-A33-3M	$\phi 5 - 8$	14000
CH-A12-5M	CH-A33-5M	$\phi 8 - 10$	
CH-A12-7M		$\phi 10 - 20$	
	CH-A33-7M	$\phi 10 - 14$	
CH-A12-11M	CH-A33-11M	$\phi 14 - 20$	
CH-A12-3L	CH-A33-3L	$\phi 5 - 8$	12000
CH-A12-5L	CH-A33-5L	$\phi 8 - 10$	
CH-A12-7L		$\phi 10 - 20$	
	CH-A33-7L	$\phi 10 - 14$	
CH-A12-11L	CH-A33-11L	$\phi 14 - 20$	

Procedure for use

- With brush rotation stopped, insert the brush into the main bore.
 - Start brush rotation when it has been inserted past the crosshole.
 - * Starting machining from a point past the crosshole while pulling the brush back will prevent burrs from being pressed flat against the inner diameter of the cylinder.
 - Machining while pulling or pushing the brush.
 - * Because the burrs are now standing, machining while pushing will reliably remove the burrs.
 - Stop the brush rotation while it is inside the cylinder.
 - After brush rotation has stopped, remove the brush from the cylinder.
- Machining in both the forward and reverse rotation directions will improve the deburring effects and provide a more even edge quality.
 - The side surface of the brush does not generate grinding power.



XEBEC TECHNOLOGY CO.,LTD.
Fuerte Kojimachi 1·7 Building 8F, 1-7-25,
Koujimachi, Chiyoda-ku, Tokyo, 102-0083, Japan
TEL. +81-3-3239-0810 FAX. +81-3-5211-8964
© 2018 XEBEC TECHNOLOGY CO.,LTD.

This document can also be viewed at the following website.
<http://www.xebec-tech.com/>

CH-A 20180802E Created in August 2018